

CASE STUDY: MODERNIZATION OF THE PATTERSON IRRIGATION DISTRICT

Stuart Styles¹, Charles Burt², Mike Lehmkuhl³, John Sweigard⁴

ABSTRACT

The Irrigation Training and Research Center (ITRC) at Cal Poly in San Luis Obispo, California has been working in conjunction with the Patterson Irrigation District (PID) on modernization of the district facilities. This project is being partially funded by the United States Bureau of Reclamation (USBR) Mid-Pacific Region. The district is located in the San Joaquin Valley of California. Water supply for the district is pumped primarily from the San Joaquin River. The district utilizes a series of pump stations and canal pools to bring water uphill to supply the lateral canals, which are laid out on the contour.

Modernization of the facilities to date have included considerable discussions with the district board members, unsteady flow simulation of the first pool in the main canal system, a new SCADA system, a large Replogle flume in the first main canal pool, remote monitoring of water levels, downstream control of the canal, the use of variable frequency drives for the pump stations, and design of flow control/measurement strategies for the heads of the lateral canals. These changes are expected to help the district improve flexibility of operation for the farmers and to decrease pumping costs for the district. This paper will provide the basic guidelines and components for a phased approach to this on-going modernization effort.

INTRODUCTION

Patterson Irrigation District (PID) pumps water from the San Joaquin River uphill into its Main Canal through a series of pump stations and pools. There are five pools along the main canal. The pool next to the river is the longest at approximately 14,000 feet (4,300 m) and the most distant pool (fifth) is the shortest. The Main Canal supplies 13 lateral canals that are located on the contour. Water can also be diverted into the district Main Canal by gravity from the Delta Mendota Canal.

¹ Project Manager, Irrigation Training and Research Center (ITRC) California Polytechnic State University (Cal Poly), San Luis Obispo, CA 93407.

² Director, ITRC, Cal Poly, San Luis Obispo, CA 93407.

³ Engineer, ITRC, Cal Poly, San Luis Obispo, CA 93407.

⁴ General Manager, Patterson Irrigation District, Patterson, CA 95363.

The size of the district is 13,225 irrigated acres (5,352 ha) and the capacity of the main pumping plant is 170 cfs (4.8 cms). There are 309 turnouts, approximately 49 miles (79 km) of open laterals, and 84 miles (135 km) of pipeline sublaterals. Figure 1 shows the layout of the Main Pump Station and Figure 2 is the overall layout of the district.



Figure 1. San Joaquin River Main Pumping Plant Showing 3 of 5 Pumps.

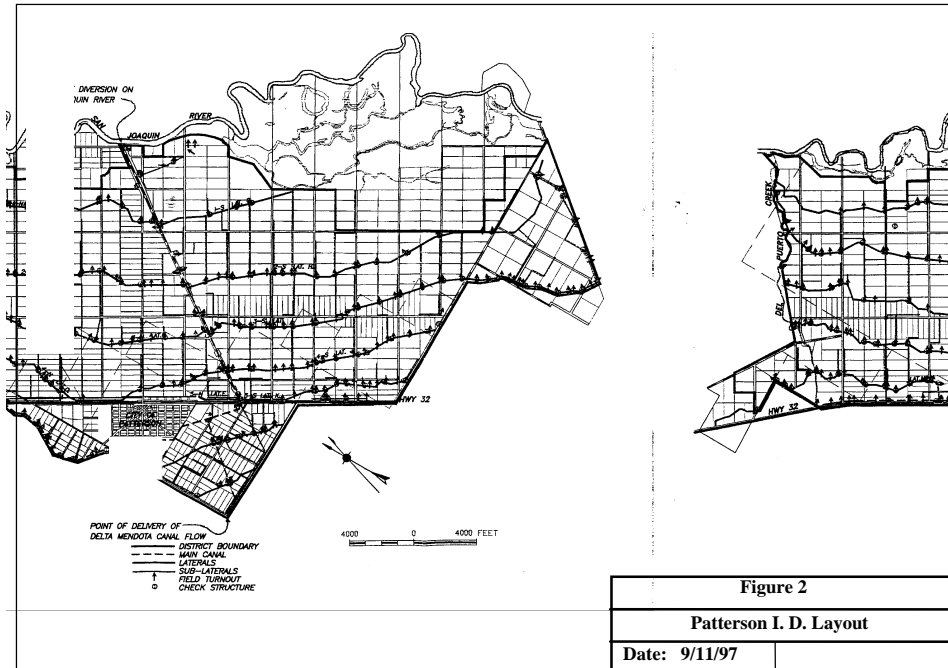

Figure 2. District Layout.

PID installed an automated pump control system for the first pump station in 1996. The original automation scheme was never modeled for hydraulic stability, and did not provide hydraulic stability. Therefore, the pumps were operated manually until the recent modernization program. When the system was running at a constant demand, the water level in the Main Canal varied by a maximum of plus or minus eight inches (± 20 cm). The actual amount of variation decreased as the length of the pool decreased.

The individual pumping sites are as follows:

1. Main Pumping Plant 1 (five pumps)
2. Pumping Plant 2 (seven pumps)
3. Pumping Plant 3 (six pumps)
4. Pumping Plant 4 (four pumps)
5. Pumping Plant 5 (four pumps)

In addition to the problems of reliability and accuracy, the original SCADA system was built on a one-of-a-kind remote terminal unit (RTU) that cannot easily be integrated into remote control monitoring, alarming, or programming. That system did have a secondary radio alarm system that was tied into a paging system. However, this provided only a general pumping plant alarm rather than a specific problem identification or remote control functions.

NEW SCADA SYSTEM

There is a need to completely replace the original control system on the five pumping plants. By using new RTUs and a common Modbus⁵ communication protocol, the field sites will be tied into the PID office through a radio communication system that will allow remote monitoring, alarms, and control. Such a system is often referred to as a Supervisory Control and Data Acquisition (SCADA) system.

The new RTUs at each pumping plant will tie into the pump contactors, water level sensors, and level cutoffs. The RTUs will then process this information and provide realtime monitoring, alarms, and control at the PID office.

A basic layout of the proposed SCADA is shown in Figure 3.

⁵ Modbus is a common communications protocol used for SCADA systems. Using Modbus allows the users system components to readily communicate with each other. This is referred to as an "open architecture" type system. This allows the user to use different manufacturers in the construction of the SCADA components.

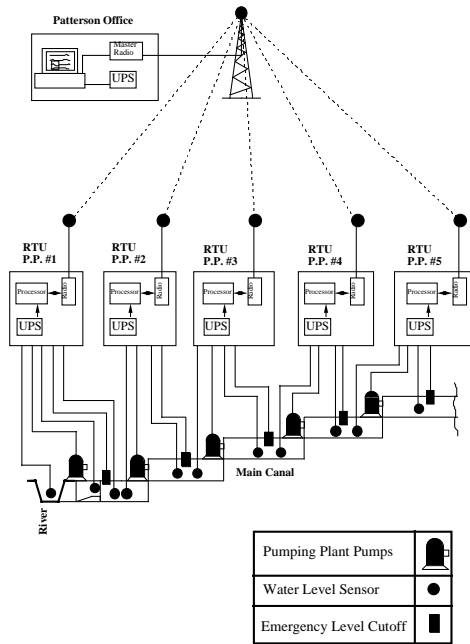

Figure 3. SCADA System Layout.

The open architecture SCADA system approach will provide the district with the following advantages:

- The district will not be tied into one system manufacturer for system expansion or replacement parts.
- The system will use an almost universal communication protocol called Modbus that will allow easy remote monitoring and control.
- The system will be expandable. The district can easily add sites or functions as needed.
- Remote Terminal Units (RTUs) will be programmed in Ladder Logic⁶ for easy understanding and troubleshooting. All programming and program editing will be completely documented and accessible by the district personnel.
- The district will have full access to change RTU programs and monitoring screen configuration.

In addition, the system can be configured to provide customized reports of past canal flows, volumes, water levels and alarms by date and time.

⁶ Ladder Logic is a programming technique which is more crude than more advanced languages such as C, but it is typically understood by field electrical specialists. Therefore, it is commonly used to program field controllers.

Because of the overall complexity of a complete district SCADA system, implementation is best accomplished in phases. This phased approach being used serves the following needs of the district:

- Allows the system to be implemented in stages that provide the maximum reliability to the district. Each stage can be evaluated and debugged before the next step is done.
- Site-by-site pump station automation. This will be based on in-depth modeling of the optimum control algorithm (control strategy) so that the pumps will cycle in a manner that provides stable water level control for demand operation in the downstream pool.
- Allows the district to become familiar with the system one section at a time.
- Allows the district to maximize its in-house personnel for installations as they become familiar with the equipment and the system.
- Allows the district maximum flexibility with critical site installations on almost an as-needed basis.

As of Summer 1999, the project is in the beginning stages of implementation. The new system is operational for the first pool of the Main Canal. The first canal pool will be operated automatically for the 1999 water season prior to full implementation on the remaining canal reaches. The project phases are described in the following section.

Project Phases

Phase 1 (Completed - April 1999):

- Develop a control algorithm for first reach of canal, using CanalCAD.
- Install a new RTU at Pumping Plant 1.
- Install a new Repogle flume at Pumping Plant 1 for flow measurement.
- Install an on-site visual display at Pumping Plant 1 for flow and volume measurement.
- Install radio and antenna at Pumping Plant 1 for remote communication.
- Install master radio and computer at the PID office configured to provide flow, volume, water levels and alarms.

Phase 2 (Completed - May 1999):

- Tie the pump contactors and sensors into the Pumping Plant 1 RTU.
- Configure for remote manual control and alarms at the PID office.
- Install a new Variable Frequency Drive (VFD) controller for the largest pump at Pumping Plant 1.

Phase 3 (In Progress - June 1999):

- Operate the first pool with only the VFD pump in automatic mode. Deliberately change the downstream flows by specific flow increments. Evaluate performance (completed as of early June).

- Tie the other 4 pumps into automatic control. Deliberately change the downstream flows by specific flow increments. Evaluate performance.

Phase 4 (Future):

- Replace the remaining RTUs at Pumping Plants 2 through 5 as needed and provide each with remote manual control and alarms at the PID office.
- Install the necessary control logic into the RTUs one at a time and convert to automatic operation. The ability to switch back (override) to remote manual control at the PID office will be retained in case of emergency.
- Evaluate operation of new SCADA system.

The following section is intended to serve as a guideline to equipment configuration. Any equipment used in this section is intended only for preliminary cost evaluations and concept. Comparable equipment of similar quality that also utilizes open architecture can be used.

Equipment Configuration

Remote Terminal Units: The individual RTUs at all five pump sites will be designed as identical or “standard” units. The only modification between units is the number of inputs for pumps and water levels. The standardization of the RTU units will provide the following:

- Simplification of parts stocking.
- Reduction of panel construction cost.
- Easier troubleshooting since all units would be exactly the same.
- Reduction of documentation.
- Capability of future expansion in all units for remote operation or automation.
- Interchangeability.
- Pumping Plant 1 will include an on-site LCD display for canal flow.

As with the RTU design and layout, the programming at each of the sites will be standardized. Set points, limits, and alarms will be set up with the variables that are accessible from the SCADA monitoring screen.

The RTU programming will incorporate the following items:

- On-site calculation of total volume (AF) and storage of this value in a non-volatile section of memory.
- On-site calculation of flow rate (CFS).
- Remote manual control of pumps.
- Alarming
 - High and low water level alarms
 - High 'high' and low 'low' water level alarms.
 - Sensor rate of change
 - Emergency high water level

- Pump failure (manual and automatic)
- Communication failure
- Conversion of all inputs to the appropriate engineering units.

At each of the sites, the RTU and related equipment will be housed in a standard 30" x 30" x 8" NEMA-4 rain-tight enclosure. This size will allow for any needed expansion needed in the future. Some of the basic equipment at each site is described below.

Un-interruptible Power Supply (UPS). Each site will be equipped with an Un-interruptible Power Supply. The UPS will provide approximately 4 hours of stand-by time with a recharge time of approximately 24 to 36 hours.

Micro-16. The project will utilize a standard Control Microsystems Micro-16 as the programmable microprocessor, with the appropriate I/O modules for site interface. The Micro-16 will allow straightforward Ladder Logic programming for simple monitoring sites and basic control and the capability to be programmed in C for the most demanding control equations.

Input and Output Modules. The Micro-16 requires additional modules to interface with the pumps and sensors.

Radio. The radio system used for the SCADA communication system is a new, unlicensed Spread Spectrum⁷ technology. This radio system operates in the 902 mhz to 928 mhz range. By "hopping" on different frequencies within this range the radio is able to greatly improve reliability.

The radio system is equipped with the following radio antennae:

- Slave field site (pumping plant) antenna is a 9 decibal (db) gain Yagi⁸ with a 25' tall mast.
- Master site (Patterson Irrigation District office) antenna is a 9db Omni Directional⁹ with a 55' to 65' mast.

Water Control Center at PID Office: The central control/monitoring center has one computer dedicated to communicating with the remote sites and displaying the information on graphical screens. This computer polls the remote sites on a 5 to 10 second interval that provides real-time site information in the district office. Lookout[®] computer software is used as the central SCADA Man Machine

⁷ Spread Spectrum is a type of radio communications that is becoming increasingly popular for SCADA systems. In some areas, this may be the most optimal communications format.

⁸ Yagi is a type of "single direction oriented" antenna used for SCADA systems.

⁹ Omni Directional is also a type of antenna used for SCADA systems. The base station requires this type of antenna since it is located near the center of the Main Canal and must receive radio signals from multiple directions.

Interface (MMI). This is the process control software that is gaining in popularity on SCADA systems. The software runs on the Windows® NT 4.0 operating system.

The general process of screen development incorporates a system that allows an operator to graphically access the information. For example, the main screen is an overview of the district that allows the operator to click at different locations on the screen for more detailed information screens for any particular site.

For the PID, the main screen is an overview of the district with "spinners"¹⁰ at each of the five pumping plant sites. The spinners indicates if any pump at the site is on or off. On the overview screen, there is also be a readout of total real-time volumes and the current Main Canal flow rate.

By clicking on any of the spinners, a second screen appears with the details of the site as follows:

- Individual pump on or off indicated by color change and spinner.
- Switches or buttons for individual pump start and stop.
- Total volume pumped to date.
- Resettable volume indicator with date last reset.
- Water level indicators.
- Individual alarm on or off switches.
- Historical trending screen for flowrates and water levels.
- Pump runtimes and pump starts.
- Alarms settings button to bring a popup screen up for changing:
 - maximum water level
 - minimum water level
 - sensor rate of change limits

Spread Spectrum Radio Testing

Cal Poly ITRC conducted preliminary radio tests between the PID district office and two potentially difficult field sites. This is an important step for any radio installation, and is something which must be done in the field.

The testing process involved setting up a temporary antenna and radio at the PID office and then going out to each of the field sites and setting up a second antenna and radio. The communication "throughput and fade margin"¹¹ were then checked.

¹⁰ Spinners are icons used by the Lookout® software to indicate that additional information is available on another computer screen about the item.

¹¹ Throughput and fade margin are standardized items to be evaluated for a Spread Spectrum radio check.

The RTU site at Pumping Plant 1 was considered to be a potential problem mainly due to its distance from the PID office (7 miles) and some obstructions directly in the communication path. The RTU site at Pumping Plant 5 was also checked.

The following equipment was used for the radio test:

PID Office

- Radio: FreeWave Spread Spectrum DGR-115
- Antenna: 9db gain yagi approximately 40 feet tall

Pumping Plant 1

- Radio: FreeWave Spread Spectrum DGR-115
- Antenna: 9db gain yagi approximately 25 feet tall
-

The results indicated that both throughput and fade margin were well within acceptable ranges at each of the sites.

CANALCAD SIMULATION RESULTS

ITRC conducted unsteady flow hydraulic simulations of the first pool of the main canal at PID with CanalCAD to determine the optimum control scheme. This modeling showed that reasonable water level control under demand downstream control would require a Variable Speed Drive controller for one of the pumps - simple single speed pump staging was inappropriate. The control logic that was finally selected uses Proportional-Integral-Derivative process control, with a modified "BIVAL" logic.

Numerous simulations were conducted to determine the optimum Proportional-Integral-Derivative coefficients and to determine the proper control logic to use. The control logic uses a time step of 1 minute.

The following is the equation used for the control algorithm:

Change in

$$Q = -(((KP + ((KI)/2)) * enow) + ((-KP + ((KI)/2)) * elast) + (KD * (enow - elast))) \quad (1)$$

where

$$enow = yest - yt$$

$$yest = 0.25 * (y1) + 0.75 * (y5)$$

y1 = depth of the canal at the start of the pool (measured just downstream of the Replogle flume)

y5 = measured depth of the canal at the downstream end of the pool

yt = the artificial target depth, located 3/4 of the distance down the pool

elast = enow on the last time step (1 minute prior)

KP, KI, and KD are tuning constants

yest, yt, y1, y5 are depths in feet

Change in Q is in units of CFS

The control depths are at yt1 and yt5. A sensor is located 75% of the distance down the pool, but its depth does not correspond to the calculated value, yest, of the algorithm. In the field, the control algorithm maintains a fairly constant value of yest, but the actual water level at the 75% distance varies. Figure 4 below shows the general location of the control points used for the evaluation.

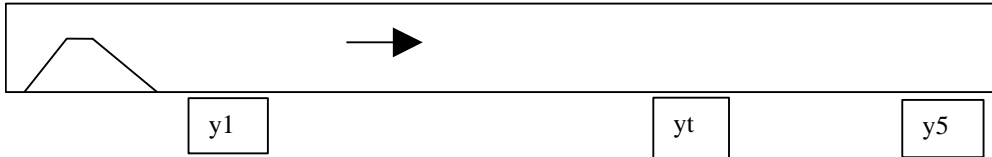

Figure 4. CanalCAD Simulation Control Points - Side View.

A sample output of the CanalCAD canal simulation program is shown in Figure 5. The graph reflects the flow rate changes by the VFD and the pump station with a change in demand on the canal.

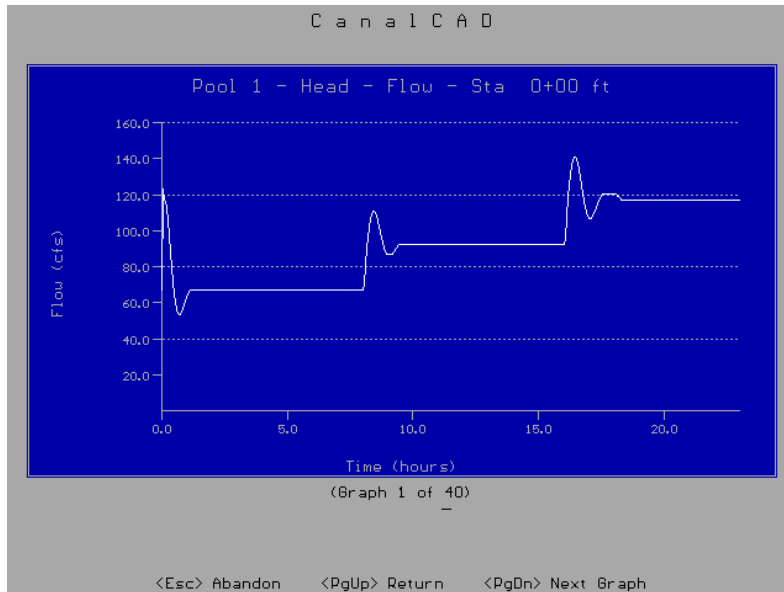

Figure 5. Sample CanalCAD Graph.

VARIABLE FREQUENCY DRIVE

ITRC recommended the use of a variable frequency drive (VFD) for Pumping Plant 1. The new VFD allows excellent control for the first reach of the canal by allowing an unlimited flow rate range. In order to properly program the RTU, the relationship between "change in pump speed" and "change in Q" must be known. In practice, this is neither a constant nor a precisely known relationship because (i) the water level in the pump forebay changes considerably during the year, and (ii) pump characteristics can change with time. ITRC used ultrasonic flow measurement equipment on the pump discharge pipes and pump affinity laws to estimate the relationship between pump speed and flow rate. The following graph illustrates the pump and system curves.

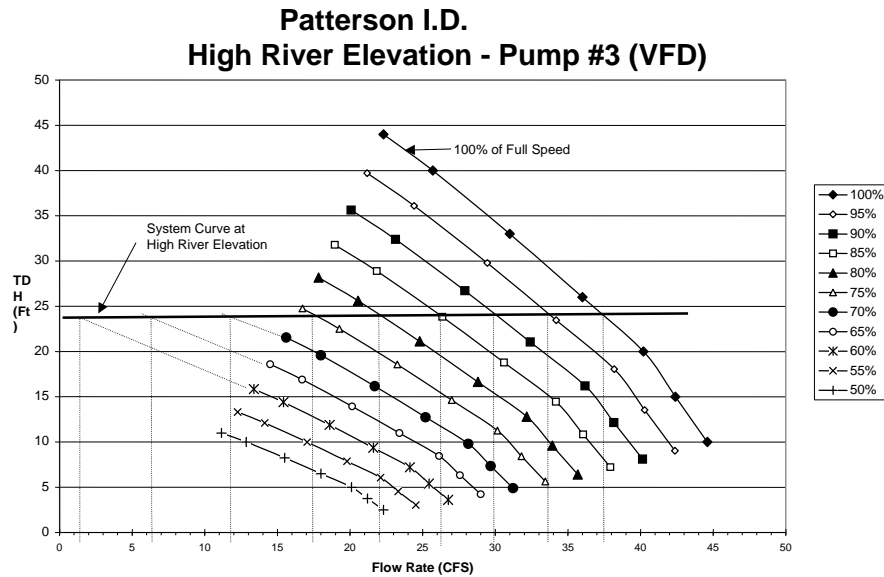

Figure 6. Variable Frequency Drive on Pumping Plant 1.

MAIN CANAL REPLOGLE FLUME

A large Replogle flume was designed and constructed at the head of the Main Canal just downstream of the Main Pumping Plant. The flume allows the district to obtain accurate flow rate and volumetric data for this key entry point. The following information was provided by the district for the design of the flume:

Survey Data

Depth of Lining = 5.6 ft	Side Slopes = 1.6 Horz:1 Vert
Bottom Width = 7.0 ft	Bottom Slope = 0.0002
HWL depth = 4.85 ft	Manning's n = 0.015 (smooth concrete)
Maximum Flow Rate = 170 CFS (Assumed potential for up to 190 CFS)	

Since the canal can have a backwater influence due to the next pump station, the flume was designed to be elevated to a height where the backwater influence would be minimized. Two elevations were investigated – a sill height of 4.0 feet and 3.5 feet.

The design selected for the Main Canal was the sill height of 4.0 feet. This will provide the best opportunity to avoid submergence problems. Placing a new approach ramp and sill to an elevation of 4.0 feet require the canal lining to be raised by 1.0 feet for the first 300 feet of the canal. The flume was placed at least 300 feet downstream from the start of the canal to satisfy the $[10xW]$ rule for the flume placement (where W is the top width of the canal.)

The design includes a downstream ramp. The slope of the ramp is 6:1. Figure 7 below shows the dimensions of the proposed structure. The ramp serves two purposes:

- 1) It provides an energy recovery function
- 2) It eliminates a vertical wall design (retaining wall type structure) at end of flume. This eliminated the need to have a structural engineer do the civil engineering design.

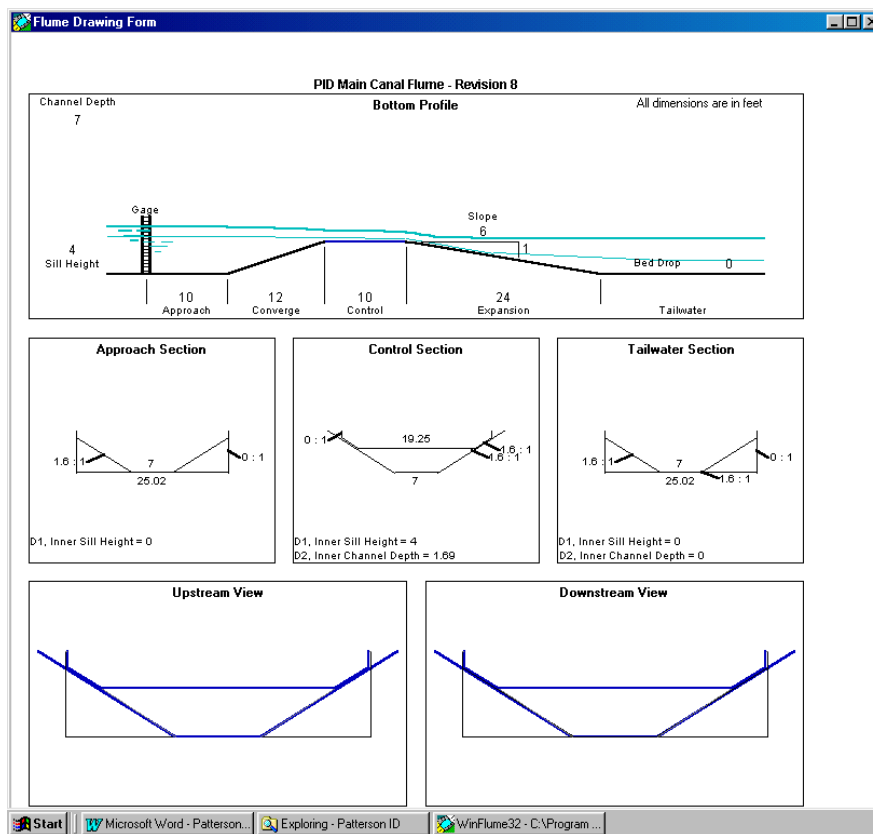

Figure 7. WinFlume 32 Output for PID Main Canal Flume.

The head variation is from 0.6 ft to 2.0 ft (0.18 m - 0.61 m) throughout the flow rate range of interest. This is a small range which is characteristic of a simple Replogle flume with only a bottom contraction. It would have been possible to increase the range of elevations for the range of discharges with the addition of side contractions. However, the design and construction complexity increases tremendously with the addition of the side contractions. Side contractions were not evaluated for this design.

A nice feature of the USDA-ARS Win-Flume computer program utilized for the design of the Replogle flume is that the program can be used to calibrate the flume after installation. The as-built dimensions can be re-entered into the computer program to precisely generate the head-discharge relationships. While not a replacement for good engineering planning and construction techniques, this does allow for a final check on the calibration of the new flume.

FLOW MEASUREMENT INTO LATERAL CANALS

Each of the lateral canal entrances was examined to determine the feasibility of eventual modernization with flow control. All but one of the lateral canals can be equipped with a small Replogle Flume. When the lateral canal headgates are automated, the flow rate will be controllable within $\pm 5\%$.

IMPLEMENTATION OF MODERNIZATION

ITRC, through its contract to provide technical assistance on behalf of the Mid-Pacific Region of the USBR, provided the conceptual framework for the controls, conducted the modeling, designed the flow measurement structures, and worked with the district manager to gain support from the PID board of directors. ITRC also worked with the district to select an integrator¹² that was responsible for the final installation. ITRC also worked with PID and the integrator on the debugging, as well as on some of the installation work.

A knowledgeable integrator is essential to such a project. First class, industrial type, off-the-shelf hardware and software must be used. The integrator must be extremely familiar with such hardware, and must have considerable experience before-hand. Furthermore, the integrator must be involved at all stages - including the planning, equipment selection, installation, and trouble-shooting.

This modernization represents a major change for PID's operation. Therefore, it is crucial that the board of directors understand the project. It is equally important that a key knowledgeable individual from the district be actively and personally

¹² An integrator is a knowledgeable contractor who can work with different SCADA component suppliers to put a complete SCADA package together.

involved in the whole project, from start to finish. In this case, the district is relatively small and the manager has a technical agricultural engineering degree and was familiar with canal automation concepts - factors which considerably smoothed the process. These projects can only be successful with a cooperative team approach, because numerous "glitches" can appear. Typically, such glitches can be quickly solved if there is a team approach to the modernization.

Below is a sample of a computer screen that is being used for the SCADA system at Patterson Irrigation District. The screen shows the water level trends and the activity of the VFD.

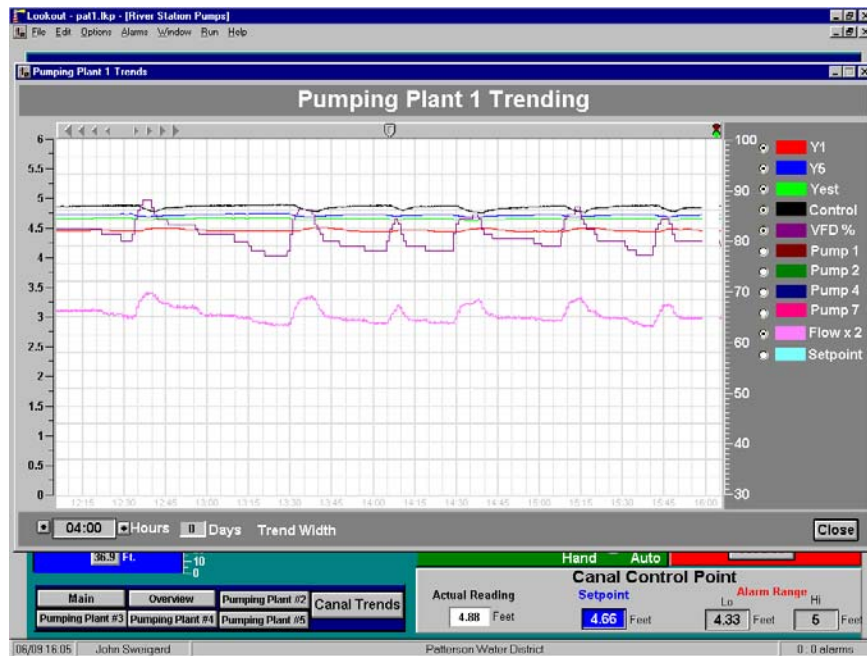

Figure 8. Sample Screen from SCADA Software.

Outside costs to the district to date have been about \$55,000 for the SCADA system components for the first phase (office control center plus one site), \$33,000 for a single VFD control, and about \$12,000 for the Replogle flume in the Main Canal. The remaining VFD installations (4 more sites) plus expanded SCADA system will probably cost about \$200,000 more. Automation and flume installation of the lateral headings will cost about \$8,000 each. If billable time for ITRC and PID management staff to date is counted, approximately \$120,000 in additional costs have been incurred. Total completed project cost for converting the 5 pump stations on the main canal to demand operation, and automated lateral headings, using remote monitoring, will be approximately \$550,000 (about \$42/acre or \$103/ha).

SUMMARY

This paper gives a brief overview of modernization efforts on a small irrigation district. Teamwork plus a deliberate and phased approach are required. Having technical expertise and the use of high quality, off-the-shelf technology are key elements in achieving success.